



# education

---

Department:  
Education  
**REPUBLIC OF SOUTH AFRICA**

## **NATIONAL SENIOR CERTIFICATE**

**GRADE 12**

**CIVIL TECHNOLOGY**

**NOVEMBER 2008**

**MEMORANDUM**

**This memorandum consists of 16 pages.**

**QUESTION 1: CONSTRUCTION PROCESSES**

- 1.1 1.1.1 Couple roof ✓ ✓ (2)
- 1.2 A Rafter ✓  
B King post ✓  
C Queen post ✓  
D Strut ✓  
E Tie beam ✓ (5)
- 1.3 Bolts and nuts ✓  
Rivets ✓  
Welding ✓ (3)
- 1.4 Battens/purlins are used to secure the roof covering (tiles and sheeting). (1)
- 1.5 1.5.1 Hand saw ✓ – Keep hands clear off the line of cut ✓  
Hammer ✓ – Do not use a hammer with a cracked handle or loose head ✓  
Square – Do not throw the tool to fellow workers, rather pass by handle  
Ratchet brace – Ensure that there is sufficient clearance for the sweep  
Tape measure – Keep fingers clear of blade when withdrawing the tape (4)
- [ANY TWO OR ANY OTHER ACCEPTABLE ANSWER]
- 1.5.2 Never use the machine without the guard ✓  
Do not tilt the machine whilst it is being used ✓  
Do not force the machine onto the work ✓  
Grip the machine firmly  
Ensure that the electric chord is away from the line of cut  
Ensure that the blade is sharp and set (3)  
[ANY THREE OR ANY OTHER ACCEPTABLE ANSWER]
- 1.6 The type of roof covering used ✓  
The roof design (1)  
[ANY ONE OR ANY OTHER ACCEPTABLE ANSWER]
- 1.7 1.7.1 Concrete tile ✓  
1.7.2 Batten ✓  
1.7.3 Plastic ✓  
1.7.4 Truss ✓  
1.7.5 Brandering ✓  
1.7.6 Ceiling board ✓ (6)

- 1.8 Glazing putty ✓  
Silicone ✓  
Timber Glazing bead  
[ANY TWO OR ANY OTHER ACCEPTABLE ANSWER] (2)
- 1.9 Ensure that you put on a latex glove before you administer any treatment. ✓  
Try to arrest bleeding as soon as possible. ✓  
Try not to come into contact with any body fluids of the injured. ✓  
Wash your hands thoroughly with warm water and soap whether you wore latex gloves or not. (3)  
**[30]**

**QUESTION 2: ADVANCED CONSTRUCTION PROCESSES**

- 2.1 2.1.1 Concrete is used in foundations ✓  
Used in slabs ✓  
Floors  
Driveways  
[ANY TWO OR ANY OTHER ACCEPTABLE ANSWER] (2)
- 2.1.2 Mortar is used in bricklaying ✓  
Mortar is used in plastering and rendering of walls ✓ (2)

2.2

SOLID BRICKS	BRICKS WITH HOLES
Bricks are heavier ✓	The holes make the brick lighter ✓
Bricks take longer to dry ✓	The holes allow the bricks to dry faster ✓
No provision to allow mortar to penetrate the bricks	The bricks lock better in position as the mortar is forced into the holes
Bricks will take longer to bake	Holes allow heat in the kiln to pass through the bricks, resulting in better burnt bricks

[ANY TWO OF THE ABOVE ALTERNATIVES] (4)

- 2.3 A dry wall consists of a frame made of suitable material such as timber, steel, aluminium, etc. ✓
- The frame is covered with a cladding which can be plywood, gypsum board, chipboard or any other appropriate material. ✓ (4)

[ANY THREE OF THE ABOVE ALTERNATIVES]

- 2.4 A Square twisted bar ✓
- B Plain round bar ✓
- C Ribbed bar ✓
- D Twisted ribbed bar ✓ (4)

2.5 2.5.1 To offer the steel protection against corrosion and extensive heat. ✓ ✓ ✓ (3)

2.5.2 The nominal cover should be equal to the diameter of the thickest bar in the group with a minimum cover of 20 mm. ✓ ✓ (2)

2.6 **Formwork** refers to the temporary support provided to forms of shape and size desired in the finished concrete construction such as columns, staircases, etc. ✓ ✓

**Shoring** refers to a timber structure used temporarily to prop or support a wall or trench that is due to collapse. ✓ ✓ (4)

- 2.7 Concrete block ✓
- Pre-stressed rib ✓
- Weld mesh ✓
- In-situ concrete ✓
- Screed
- [ANY FOUR OR ANY OTHER ACCEPTABLE ANSWER] (4)

2.8 2.8.1

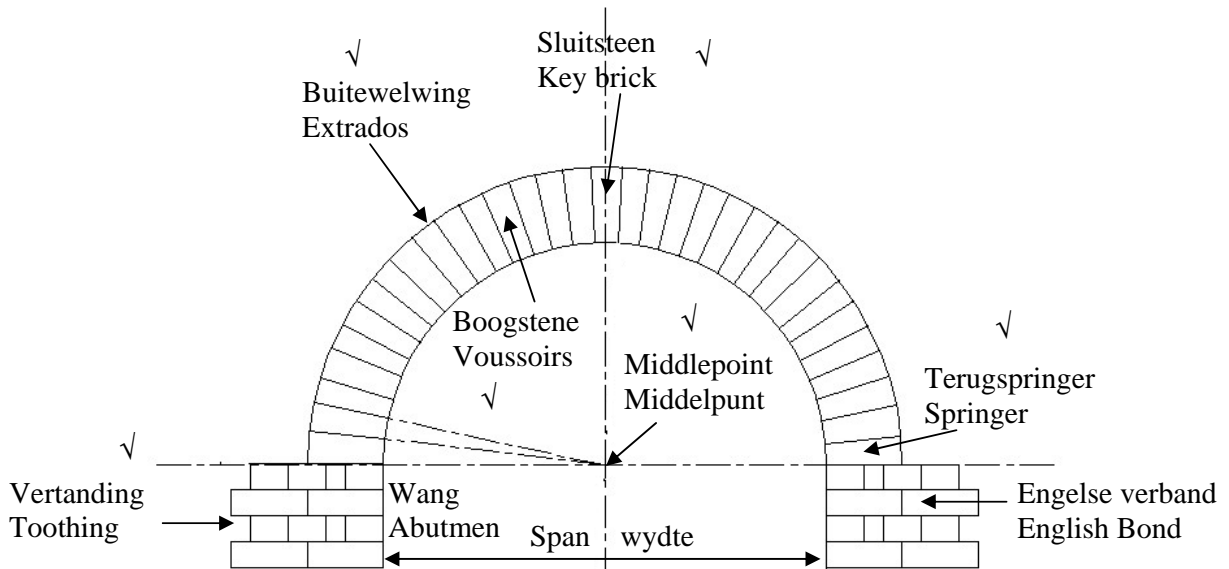

FIGURE 2.9

[FOUR MARKS ARE ALLOCATED TO THE DRAWING AND SIX MARKS FOR ANY OF THE REQUIRED LABELS] (10)

MARK ALLOCATION FOR DRAWING	MARKS
Arch	2
Brick work-English bond	1
Neatness	1
<b>TOTAL</b>	<b>4</b>

- 2.8.2 Semi-circular center OR semi-circular timber shape. ✓ (1)  
[40]

### QUESTION 3: CIVIL SERVICES

- 3.1 be self cleaning ✓  
have an adequate water seal ✓  
be simple in design and free of angles, so that the flow of water is not retarded ✓  
be of uniform bore  
not corrode  
be of the same diameter as the waste pipe  
be easily connected to the fitment (3)  
[ANY THREE OF THE ABOVE]

- 3.2 Install an anti-syphon trap (resealing trap) ✓  
Correct use and installation of vent pipes (1)  
[ANY ONE OF THE ABOVE]

- 3.3 P-trap: ✓ used in a sink, wash hand basin, urinal, etc. ✓  
S-trap: ✓ used in wash hand basin ✓  
Bottle trap: used in a wash hand basin, urinal, etc. (4)  
[ANY TWO OF THE ABOVE]

- 3.4 **Purpose**  
  - It enables the plumber to detect the point of obstruction in the waste water line from where he is rodding. ✓
  - It enables obstructions to be cleared by rodding. ✓
  - It allows access for a probe to locate interferences and cracks in the system.
  - It gives the plumber easy access to rod through blockages.
  - It prevents unnecessary excavations in case of blockages. (2)

- Advantage**  
  - It is much cheaper to install than a manhole ✓
  - It is small and neat compared to a manhole ✓ (2)

[OR ANY OTHER APLLICABLE ANSWER]

- 3.5 Gravity system ✓ - on farms where no high pressure water supply is available ✓  
- small quantities of water is still available although the water supply has been interrupted, etc

**OR**

- Pressure system - it accommodates modern mixer taps  
- higher flow rate of water (2)

**OR**

(ANY OTHER APPLICABLE ANSWER)

[ALLOCATE ONE MARK FOR THE CHOICE AND ONE FOR THE MOTIVATION]

- 3.6 Cold water is supplied to the geyser by means of a pressure reducing valve. ✓  
The cylinder consists of a container with water inside with a heater element and thermostat. ✓  
The water is heated to a set temperature on the thermostat. ✓  
If the temperature of the water falls below the set temperature, the thermostat automatically switches on the electric current. ✓  
This allows the element to bring the water to the required temperature,  
When the set temperature is reached, the thermostat switches off the current, and the hot water in the cylinder is stored ready for use.  
High pressure geysers are fitted with a temperature and safety valve for safety purposes.  
In the case of solar geysers the energy from the sun is used to heat the water to a certain temperature.  
A solar geyser has the same components as an electric geyser to supply hot water during cloudy weather. (4)  
[ANY FOUR OF THE ABOVE]
- 3.7 3.7.1 Ready supply of hot water. ✓  
Draw off points can be at any position in the home. ✓  
One geyser can accommodate a number of draw off points. (2)  
[ANY TWO OF THE ABOVE]
- 3.7.2 High running costs – electricity. ✓  
There is no supply of hot water if there are prolonged electricity cuts.  
Provision must be made for accommodating the cylinder. (1)  
[ANY ONE OF THE ABOVE]
- 3.8 Waste water has chemicals which will destroy the bacteria action in the septic tank. ✓  
The septic tank could be filled to capacity and may cause a blockage. (1)  
[ANY ONE OF THE ABOVE]
- 3.9 Using solar power as an alternative source of power. ✓ ✓  
Using appliances only when necessary. ✓ ✓  
Using of low energy light bulbs. (4)  
[ANY TWO OF THE ABOVE OR ANY OTHER SUITABLE ANSWER]
- 3.10 It is used to trap the grease and fat discharged into the waste water system (sewer) to prevent blockages due to fat accumulation. ✓  
It is installed at the gully of kitchens in hotels, hostels, restaurants, etc. where large amounts of grease are discharged into the waste fitment. ✓ (2)

- 3.11 Boreholes ✓  
Wells ✓  
Rain water  
Snow  
Rivers (2)  
[ANY TWO OF THE ABOVE OR ANY OTHER SUITABLE ANSWER] [30]

**QUESTION 4: MATERIALS**

- 4.1 4.1.1 B ✓ (1)  
4.1.2 D ✓ (1)  
4.1.3 B ✓ (1)  
4.1.4 D ✓ (1)  
4.1.5 B ✓ (1)

4.2

MATERIAL	ADVANTAGE	DISADVANTAGE
Galvanised pipes	Does not rust easily. ✓ Can be used underground.	It will rust if the zinc coating is damaged. ✓ Cannot be bent. Joints are necessary at changes of direction.
Copper pipes	Does not rust easily. ✓ Can be bent. No threading is required. Can be used underground.	Expensive. ✓
Plastic pipes	Will not rot or rust. ✓ It is lightweight. It is flexible. It is non-metallic.	Not suitable for hot water supply. ✓ Can only be used with compression joints. It needs to be supported at smaller intervals. ✓

(6)

[ANY ONE OF THE ABOVE IN EACH ROW, OR ANY OTHER SUITABLE ANSWER]

- 4.3 It comes readily mixed ✓  
It saves time ✓  
It saves labour  
Certificate of strength of the concrete is issued by the supplier  
Consistency of mix is maintained (2)  
[ANY TWO OF THE ABOVE]

- 4.4 It is strong and can resist a very high compressive stress. ✓  
Its tensile strength is very good. ✓  
It is watertight. ✓  
It is durable.  
It is resistant to weathering.  
It is resistant to shock.  
It is stable. (3)  
[ANY THREE OF THE ABOVE]

- 4.5 Poor mix proportions ✓  
 Poor mixing of concrete  
 Poor compaction ✓  
 Insufficient steel cover  
 Segregation of materials  
 Fire  
 Excessive compaction (3)  
 Poor curing  
 [ANY THREE OF THE ABOVE]

- 4.6 Mechanical grading ✓  
 Visual grading ✓ (2)

4.7

TIMBER	PROPERTY	USE
S A pine	Rots easily if not treated / preserved. ✓ Tendency to warp. Fairly straight grain. Softwood Takes nails well.	Roof construction ✓ Scaffolding Formwork Ceiling construction Partitions
Meranti	Light brown to reddish brown in colour ✓ Straight open grain Takes nails / screws well Has a tendency to warp Durable	Door and frame construction ✓ Window construction Skirting Architraves

(4)

[ANY ONE OF THE ABOVE FOR EACH CATEGORY]

- 4.8 Internal measurements:  
 Length:  $4\,200\text{ mm} - (2 \times 220\text{ mm}) = \underline{3\,760\text{ mm}}$  (3,76 m) ✓  
 Width:  $3\,600\text{ mm} - (2 \times 220\text{ mm}) = \underline{3\,160\text{ mm}}$  (3,16 m) ✓

$$\begin{aligned}\text{Floor area} &= 3,76\text{ m} \times 3,16\text{ m} \\ &= \underline{11,88\text{ m}^2} \checkmark\end{aligned}$$

$$\begin{aligned}\text{Area of a tile} &= 0,30\text{ m} \times 0,30\text{ m} \checkmark \\ &= \underline{0,09\text{ m}^2}\end{aligned}$$

$$\text{No. of tiles required} = \frac{11,88\text{ m}^2}{0,09\text{ m}^2}$$

$$= \underline{132\text{ tiles}} \checkmark$$

(5)

**THE METHOD BELOW IS ALSO ACCEPTABLE**

A	B	C	D
1/	3,76 ✓		<b>Area of floor:</b>
	3,16 ✓		$4\,200 - 2(220) = 3\,760\text{ mm} = 3,76\text{ m}$
		$\underline{11,88\text{ m}^2} \checkmark$	$3\,600 - 2(220) = 3\,160\text{ mm} = 3,16\text{ m}$
			<b>Area of tile:</b>
1/	0,3		$300\text{ mm} \times 300\text{ mm} (0,30\text{ m} \times 0,30\text{ m}) = 0,09\text{ m}^2$
	0,3		
		$\underline{0,09\text{ m}^2} \checkmark$	
			<b>No of tiles required:</b>
			$11,88\text{ m}^2 \div 0,09\text{ m}^2 = \underline{132\text{ tiles}} \checkmark$

**[30]**

**QUESTION 5: APPLIED MECHANICS**

5.1 5.1.1 Shear force diagram

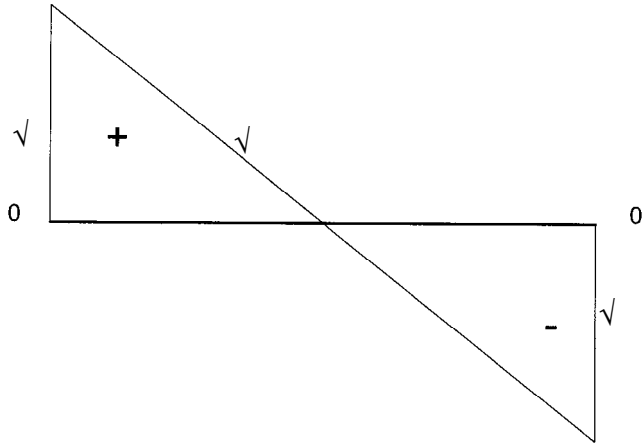

(3)

5.1.2 Bending moment diagram

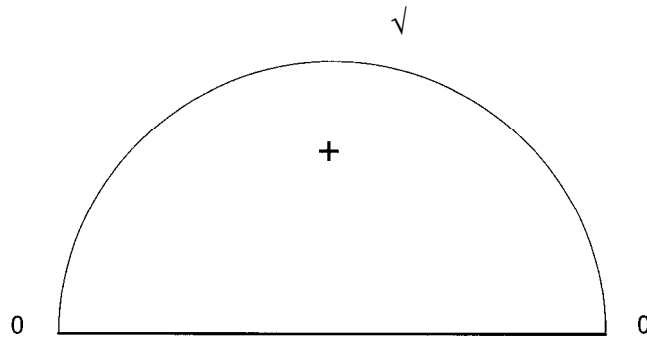

(1)

5.2.1 Force diagram

**ANSWER SHEET 5.2.1**

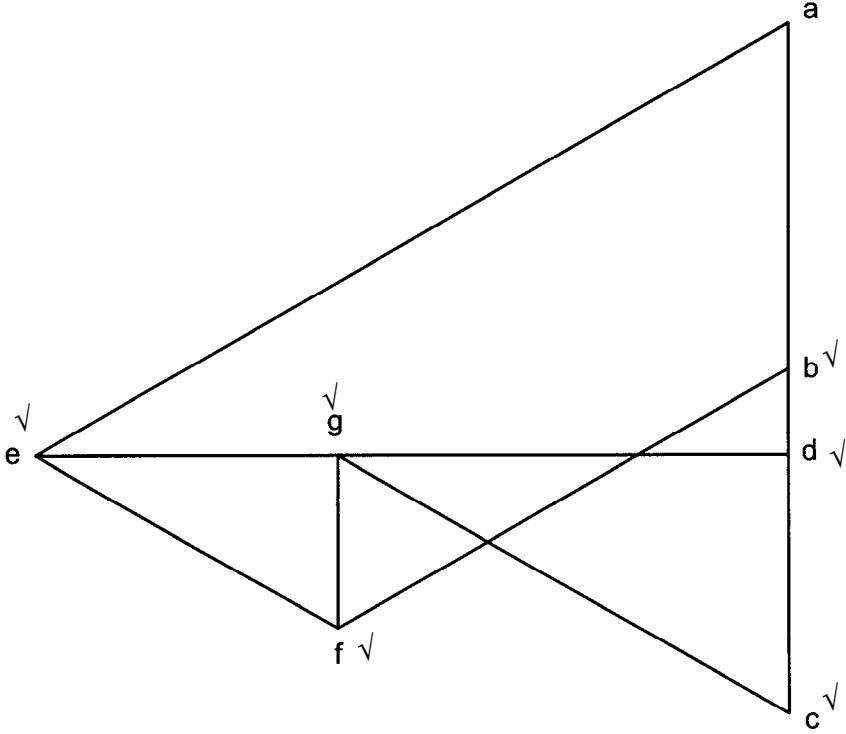

**(Not to scale)**

(6)

## 5.2.2

✓

**ANSWER SHEET 5.2.2**

✓

✓

MEMBER	MAGNITUDE	NATURE
AE	75 N ✓	Strut ✓
BF	45 N ✓	Strut ✓
CG	45 N ✓	Strut ✓
DE	65 N ✓	Tie ✓
DG	39 N	Tie
EF	30 N	Strut
FG	15 N	Tie

(14)

$$\begin{aligned}
 5.3.1 \quad \text{Area} &= \frac{1}{2} (\text{base} \times \text{height}) \\
 &= \frac{1}{2} (80 \text{ mm} \times 90 \text{ mm}) \checkmark \\
 &= \underline{3\,600 \text{ mm}^2} \quad \checkmark \qquad (2)
 \end{aligned}$$

$$\begin{aligned}
 5.3.2 \quad (a) \quad &\text{Take moments from the bottom} \\
 &\text{Area} \times \text{Distance} = 3\,600 \text{ mm}^2 \times 30 \text{ mm} \\
 &\text{Distance} = \frac{108\,000 \text{ mm}^3}{3\,600 \text{ mm}^2} \quad \checkmark \\
 &= \underline{30 \text{ mm}} \quad \checkmark \qquad (2)
 \end{aligned}$$

$$\begin{aligned}
 (b) \quad &\text{Take moments from the right hand side} \\
 &\text{Area} \times \text{Distance} = 3\,600 \text{ mm}^2 \times 40 \text{ mm} \\
 &\text{Distance} = \frac{144\,000 \text{ mm}^3}{3\,600 \text{ mm}^2} \\
 &= \underline{40 \text{ mm}} \quad \checkmark \quad \checkmark \qquad (2)
 \end{aligned}$$

**OR**

$$\begin{aligned}
 \text{Centroid from the bottom} &= \frac{\text{Area} \times \text{distance}}{\text{Total Area}} \\
 &= \frac{3\,600 \text{ mm}^2 \times 30 \text{ m}}{3\,600 \text{ mm}^2} \quad \checkmark \\
 &= 30 \text{ mm} \quad \checkmark
 \end{aligned}$$

$$\begin{aligned}
 \text{Centroid from the right hand side} &= \frac{\text{Area} \times \text{distance}}{\text{Total Area}} \\
 &= \frac{3\,600 \text{ mm}^2 \times 40 \text{ m}}{3\,600 \text{ mm}^2} \quad \checkmark \\
 &= 40 \text{ mm} \quad \checkmark \qquad \qquad \qquad \mathbf{[30]}
 \end{aligned}$$

**QUESTION 6: GRAPHICS & COMMUNICATION**

**ANSWER SHEET 6.1**

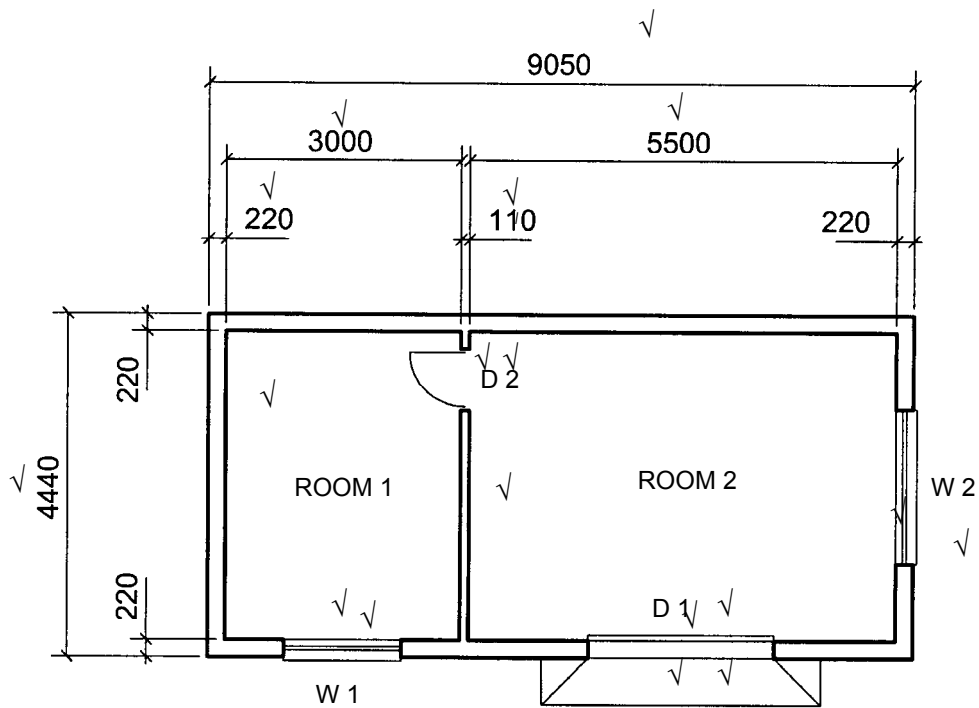

**FLOOR PLAN**

**SCALE 1:1**

(20)

**(NOT TO SCALE)**

**QUESTION 6.2**

**ANSWER SHEET 6.2**

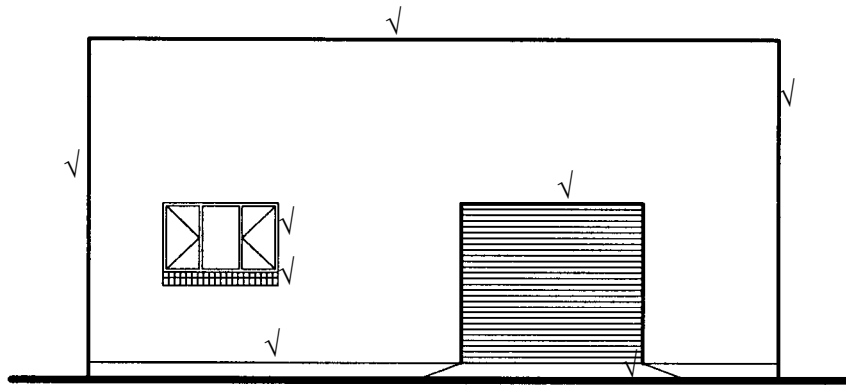

**SOUTH ELEVATION**      **SCALE 1:100**

(10)

Length	1
Height	2
Window	1
Window sill	1
Floor line	1
Ramp	1
Roll-up door	1
South elevation	1
Scale	1
<b>Total</b>	<b>10</b>

**(NOT TO SCALE)**

**QUESTION 6.3**

**ANSWER SHEET 6.3**

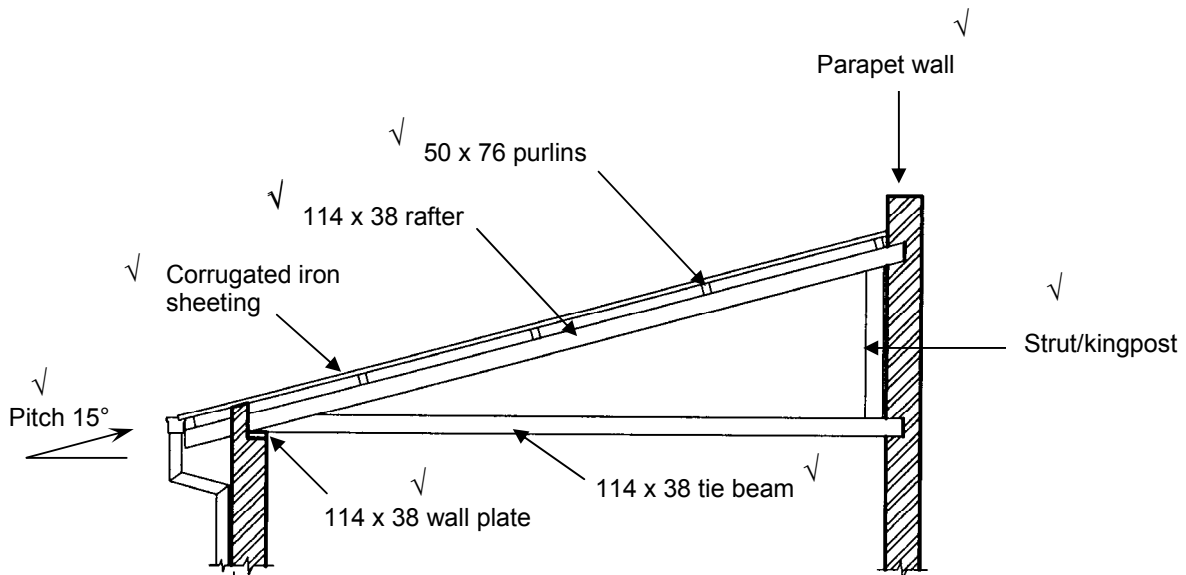

Correctness of the drawing = 1 ✓

Correct scale = 1 ✓

**(NOT TO SCALE)**

(10)  
**[40]**

**GRAND TOTAL: 200**