



education

Department:
Education
REPUBLIC OF SOUTH AFRICA

**NATIONAL
SENIOR CERTIFICATE**

GRADE 12

CIVIL TECHNOLOGY

EXEMPLAR 2008

MARKS: 200

TIME: 3 hours

This question paper consists of 11 pages, 5 answer sheets and a formula sheet.

REQUIREMENTS:

1. Drawing instruments
2. A non-programmable pocket calculator

INSTRUCTIONS AND INFORMATION

1. This question paper consists of SIX questions.
2. ALL questions are COMPULSORY.
3. Answer each question as a whole, do NOT separate sub-questions.
4. Start EACH question on a NEW page.
5. Sketches may be used to illustrate your answers.
6. ALL calculations and written answers must be done in the ANSWER BOOK.
7. Drawings and sketches must be fully dimensioned and neatly finished off with descriptive titles and notes to conform to the SANS/SABS Recommended Practice for Building Drawings.
8. For the purpose of this question paper, the size of a brick should be taken as 220 mm x 110 mm x 75 mm.
9. Use your discretion where dimensions and/or details have been omitted.
10. Non-programmable pocket calculators may be used.
11. Answer QUESTIONS 4.7, 5.4, 6.1, 6.2 and 6.3, on the answer sheets provided using drawing instruments where necessary.
12. Write your examination number on the ANSWER SHEETS and hand them in with your ANSWER BOOK. (Put ALL answer sheets inside your ANSWER BOOK.)

QUESTION 1

- 1.1 List the different stages/parts of the sub-structure of a building. (5)
- 1.2 Draw a neatly labelled single-line diagram of a South African (Howe) roof truss. (6)
- 1.3 List FOUR types of equipment that can be used to transport tools and equipment to workmen working at a high level in a high-rise building. (4)
- 1.4 Explain the sequence involved in the placing and securing of roof trusses onto the walls of a building. (5)
- 1.5 You are a carpenter and joiner on site and you are required to manufacture the roof trusses and erect the roof for the building. The external measurement of the building is 5 metres long and 3 metres wide. The South African (Howe) roof trusses are spaced at 650 mm centres. The eaves have an overhang of 500 mm beyond the 220 mm external walls.
- 1.5.1 Draw to scale 1:50 the floor plan of the building. Indicate on the plan the layout of the roof trusses as single lines. (5)
- 1.5.2 From your drawing determine the following:
- (a) The number of roof trusses required for the building (2)
 - (b) The number of rafters required for the construction of the roof (3)
- [30]**

QUESTION 2

2.1 In the building industry concrete is a commonly used material. It is used in foundations, slabs, columns and beams. Explain why it is necessary to reinforce concrete by means of reinforcement. (4)

2.2 Explain the following description for dimensioning reinforcing bars:
8 R 1001 – 200 (5)

2.3 FIGURE 2.3 shows a simple reinforced concrete beam.

The following reinforcement is used:

Two main bars of 20 mm diameter
Two anchor bars of 12 mm diameter
One shear reinforcement bar of 20 mm diameter
Stirrups/Binders of 8 mm as needed for the beam

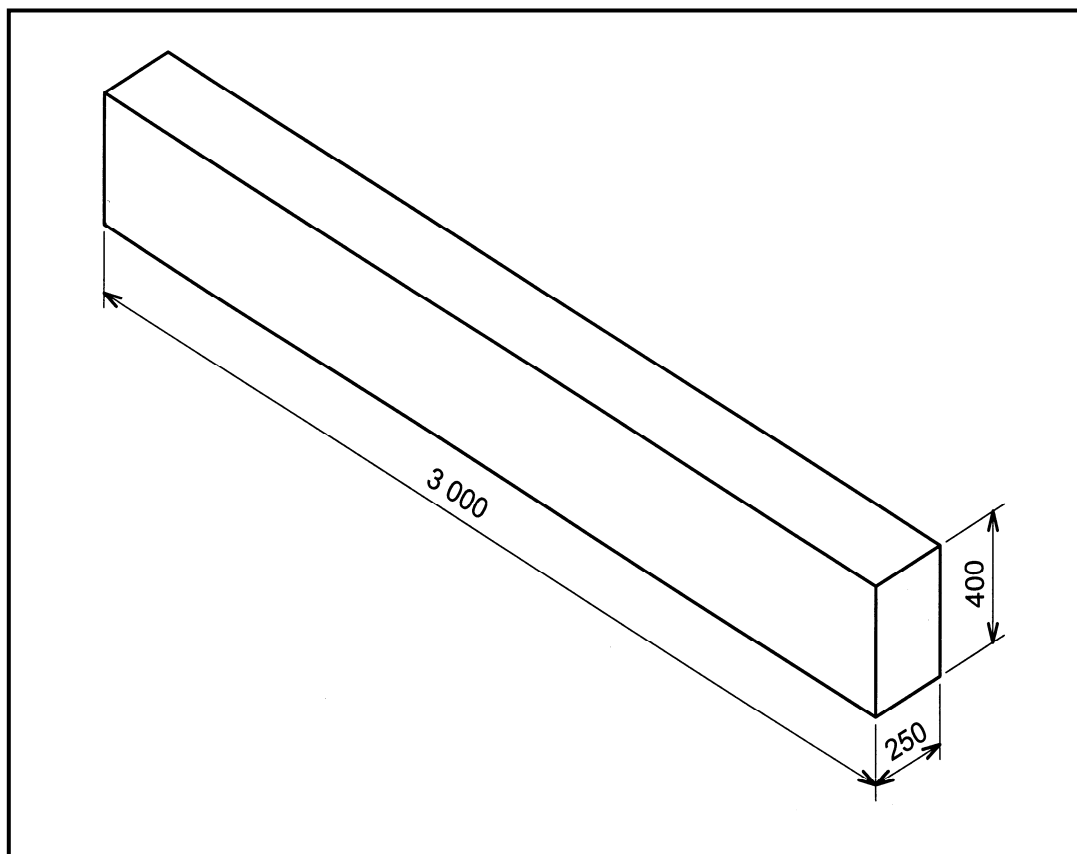

FIGURE 2.3

2.3.1 Draw, to scale 1:20, a longitudinal section to show the necessary reinforcement in the concrete beam. (Label your drawing.) (10)

2.3.2 Draw, to scale 1:5, a cross section through the middle of the beam showing the reinforcement. (7)

- 2.4 Formwork for concrete in situ may be described as a mould or box for a beam or column into which wet concrete can be poured and compacted so that it will flow and finally set to the inner profile of the box or mould.
- 2.4.1 To be effective for its intended purpose, formwork must meet certain requirements.
List any THREE requirements that good formwork should satisfy. (3)
- 2.4.2 State the name of ONE material that will be suitable for use as a lining in formwork. (1)
- 2.5 You are a builder and your client wants a low-cost arch built in his entrance hall. You decide to build a two-ringed rough semi-circular arch.
- 2.5.1 Make a neat freehand sketch to show the surrounding brickwork in any bond, two rings, springing point, centre and extrados. (6)
- 2.5.2 Differentiate between a *rough arch* and a *gauged arch*. (4)
- [40]**

QUESTION 3

Mr Kidi has been operating a successful bed and breakfast business for years. Most of his clients are tourists who visit the Pilanesberg Game Reserve in North West. Recently he has been experiencing problems with the drainage system on his property.

- 3.1 Mr Kidi was advised by one of his guests who is a plumber, to have a grease trap installed.
- 3.1.1 What is the purpose of a grease trap? (2)
- 3.1.2 Where in a sewerage system would one install a grease trap? (1)
- 3.2 Septic tanks and conservancy tanks are alternatives to waterborne sewerage systems.
- 3.2.1 In your own words explain what a *conservancy tank* is and how this system functions. (4)
- 3.2.2 Explain how a septic tank functions. (5)
- 3.3 South Africa is experiencing a serious shortage of electricity and there is a national call to encourage consumers to save electricity. In trying to save electricity, Mr Kidi installed a solar collector for heating water as an alternative to an electric geyser.
- 3.3.1 Explain how a solar water heating system works. (4)
- 3.3.2 What factors should be taken into consideration when installing solar water heating systems? (6)
- 3.3.3 Gas appliances are alternatives to electrical appliances used in a house.
- What advantage does a refrigerator operating on gas has over one operating with electricity? (2)
- 3.4 List FOUR possible ways in which storm water from a roof of a dwelling can be disposed of. (4)
- 3.5 What will be the effect on the environment and the building if storm water is not correctly disposed of? (2)

[30]

QUESTION 4

4.1 The storage of cement on site is very important.

List THREE possible effects moisture can have on cement if the necessary precautions are not applied during storage. (3)

4.2 Differentiate between the properties of *thermoplastic plastic* and *thermosetting plastic*. (4)

4.3 FIGURE 4.3 below shows the plan of a concrete column and a brick wall. In some instances a gap is left between the wall and column as shown in the sketch. Study the sketch and answer the following questions.

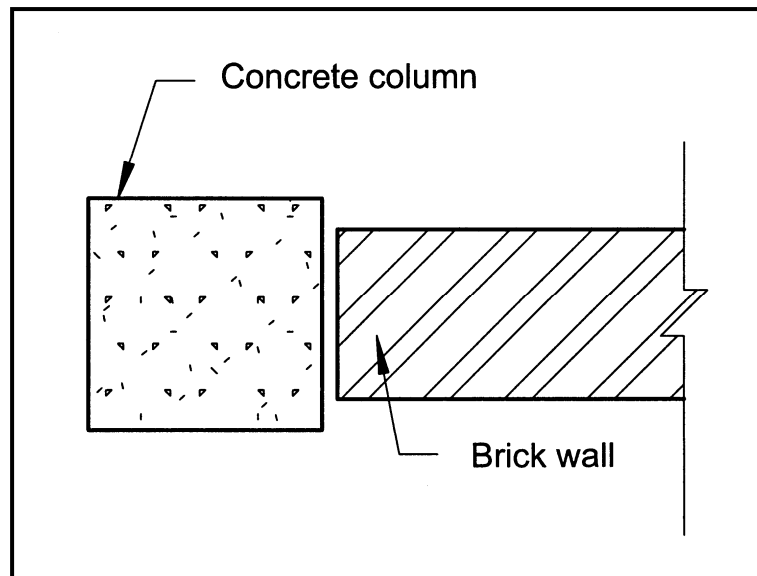

FIGURE 4.3

4.3.1 What is the gap called and state the purpose of the gap? (2)

4.3.2 List THREE materials that can be used to seal the gap. (3)

4.4 List THREE risks that are associated with using adhesives. (3)

4.5 The use of mastic products is gaining popularity in the building industry. State TWO conditions that surfaces which receive mastic products must satisfy so that good adhesion is possible. (2)

4.6 A paint vehicle is defined as the liquid part of a paint that will allow the paint to be applied to a surface.

List THREE chemicals/liquids that can be used as vehicles in paints. (3)

4.7 You are a quantity surveyor and are expected to calculate the quantity of materials required to erect the ceiling for the building illustrated in FIGURE 4.7. The ceiling battens are spaced maximum 450 mm apart. Use ANSWER SHEET 4.7 and calculate the following quantities:

- 4.7.1 The quantity of ceiling boards in m^2 that will be needed for this building (5)
- 4.7.2 The quantity of brandering that will be needed for this building (5)

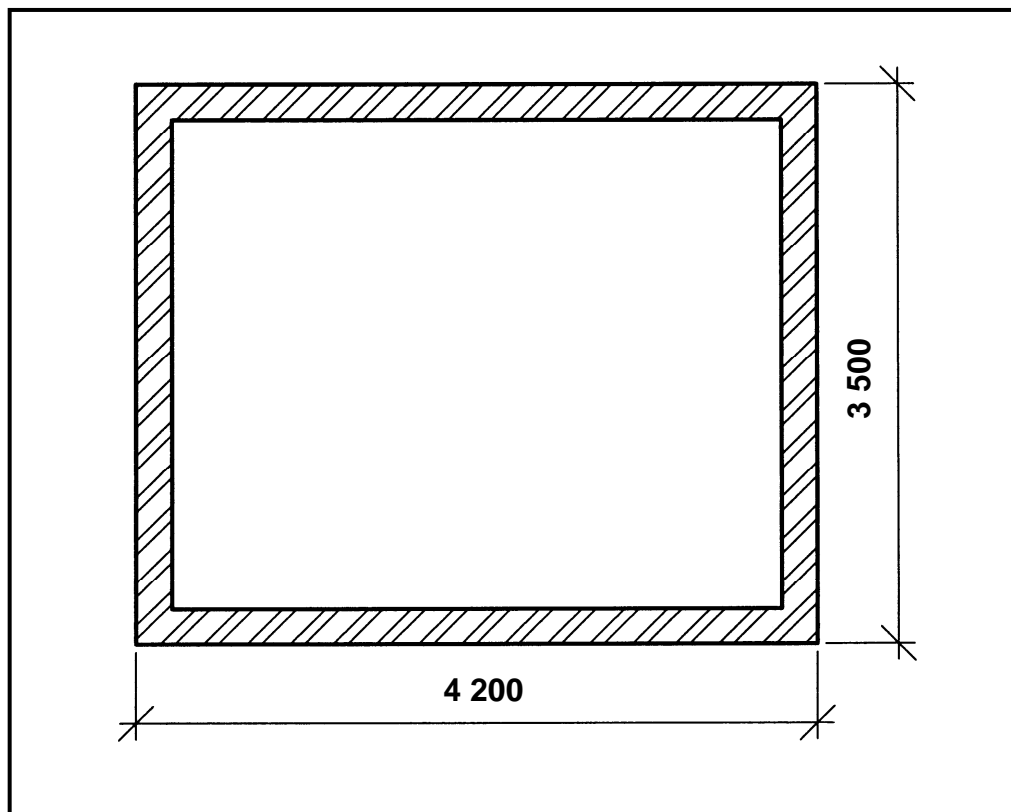

FIGURE 4.7

[30]

QUESTION 5

- 5.1 In order to comply with the SI units that are generally used, one needs to know both the unit and its symbol.

In the table below, write down the symbols for the units indicated.

	UNIT	SYMBOL
Length	Metre	5.1.1 ...
Energy	Joule	5.1.2 ...
Weight	Newton	5.1.3 ...
Force	Newton	5.1.4 ...

(2)

- 5.2 Differentiate, with the aid of diagrams, between the following:

5.2.1 Tensile force (2)

5.2.2 Compression force (2)

5.2.3 Shear force (2)

- 5.3 Beam AE is 6,5 metres long and is supported 1,5 metres from end A and at end E, as shown in FIGURE 5.3.

Take the bending moments at A = 0 kN and E = 0 kN.

5.3.1 Calculate the bending moments at B, C and D. (3)

5.3.2 Make a freehand sketch of the bending moment diagram for the beam (no scale is required). (2)

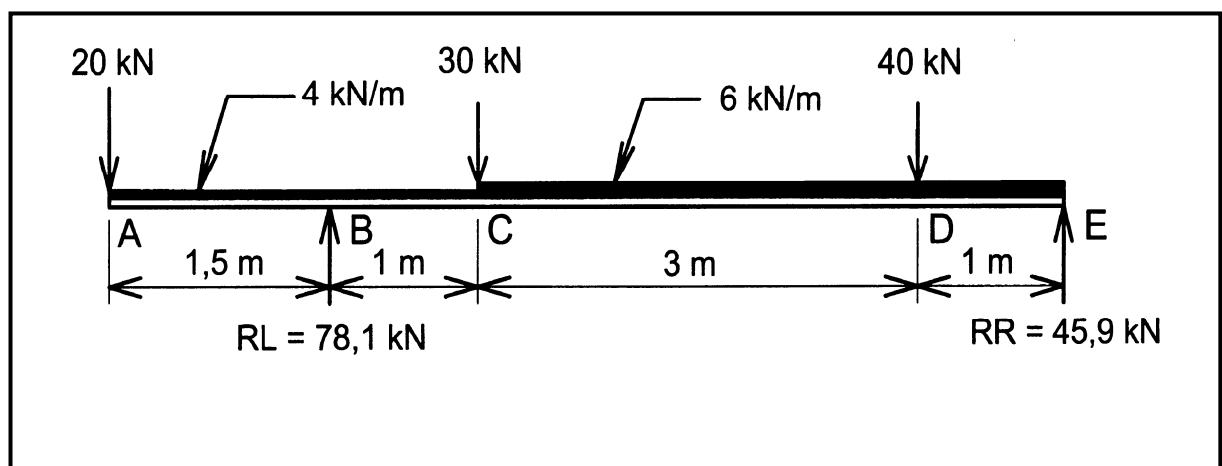

FIGURE 5.3

5.4 A simple framework is given in FIGURE 5.4. Graphically determine the magnitude and nature of forces in the members of the framework and tabulate your answers. Use ANSWER SHEET 5.4 to answer this question.

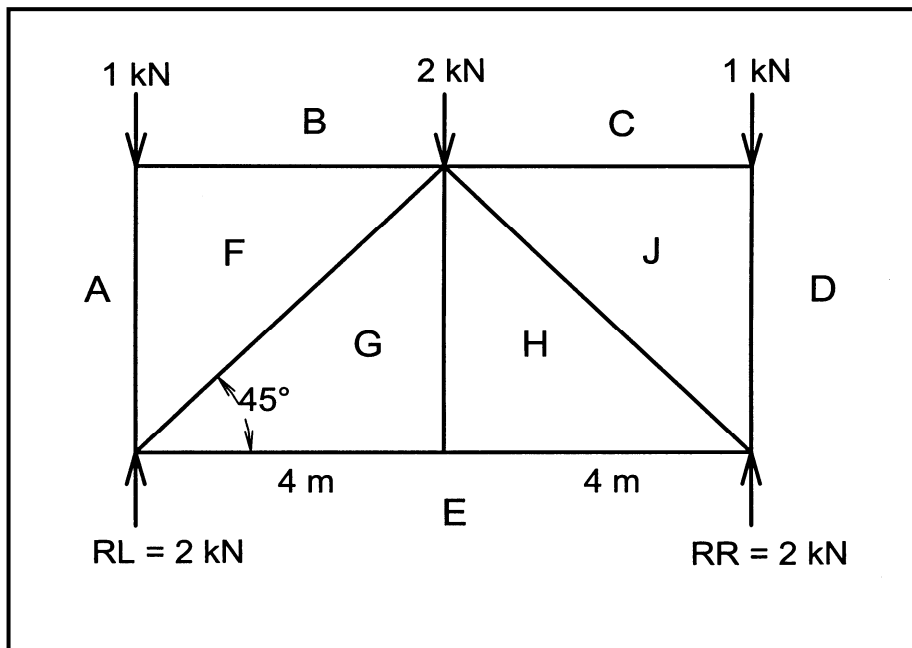

FIGURE 5.4

(7)

5.5 Define the following terms:

5.5.1 Modulus of elasticity

(2)

5.5.2 Stress

(1)

5.6 FIGURE 5.6 shows a lamina of even thickness.

Area 1 = 2 250 mm²; Area 2 = -706,86 mm²;
Area 3 = -262,50 mm²;
Area 4 = 1 925,00 mm²

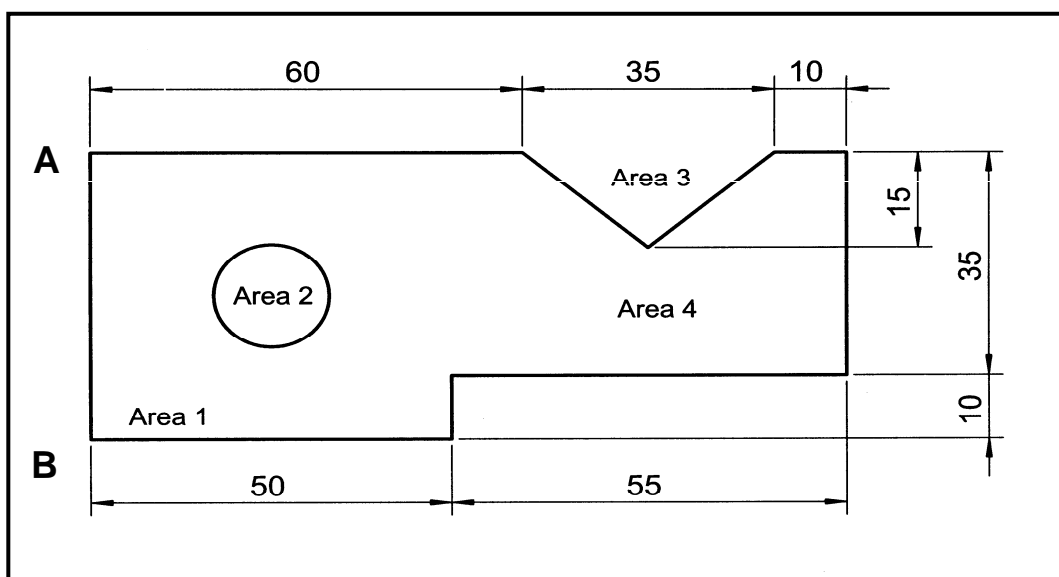

FIGURE 5.6

- 5.6.1 Determine the total area of the lamina. (2)
- 5.6.2 Determine the position of the centroid from line AB.
The total volume, area x thickness = 167 422,25 mm³. (5)
- [30]**

QUESTION 6

ANSWER THIS QUESTION ON THE ATTACHED ANSWER SHEETS PROVIDED.

Assume that you are a draughtsman and a client approaches you to design a house for him.

FIGURE 6.1, on the attached ANSWER SHEET, shows the plan of your client's proposed house.

The house has a corrugated iron gable roof pitched at 30°. The eaves have an overhang of 500 mm. The walls are 2 700 mm high, measured from the floor to the underside of the wall plate. The foundation wall projects four courses above the ground level. The walls of the house are plastered internally and are built with face brick externally.

The entrance door to the house is a framed ledged and braced batten door. The steel-framed windows for the living room and bedrooms are 1 500 mm high and the windows for the bathroom and kitchen are 600 mm high. The sliding door is a standard 3 000 mm steel-framed door. The foundations are 600 x 200 mm and two courses of brickwork above the foundation must be under the natural ground level.

Provide the section and views with the necessary notes on construction, materials and finishes (walls, ceilings and floors).

- 6.1 Show the following dimensions on FIGURE 6.1 on ANSWER SHEET 6.1 of the **southern side** of the building on the plan:
- 6.1.1 The thickness of the external walls (2)
- 6.1.2 The thickness of the internal walls (1)
- 6.1.3 The length of the bedroom (1)
- 6.1.4 The length of the kitchen (1)
- 6.2 Draw to scale 1:50, a vertical section through the house on section line A-A on the attached ANSWER SHEET 6.2. Draw **ONLY** the left-hand side of the section (5,5 m from the outer wall on the left-hand side to where the section terminates). (15)
- 6.3 Draw to scale 1:100 the north elevation and east elevation of the house on the attached ANSWER SHEET 6.3. (No gutter and down pipes must be shown.) (20)
- [40]**

TOTAL: 200

ANSWER SHEET**QUESTION 5.4**

MEMBER	MAGNITUDE	NATURE
AF		
FG		
GE		
JC		
HJ		

EXAMINATION NUMBER: _____

ANSWER SHEET

QUESTION 6.1

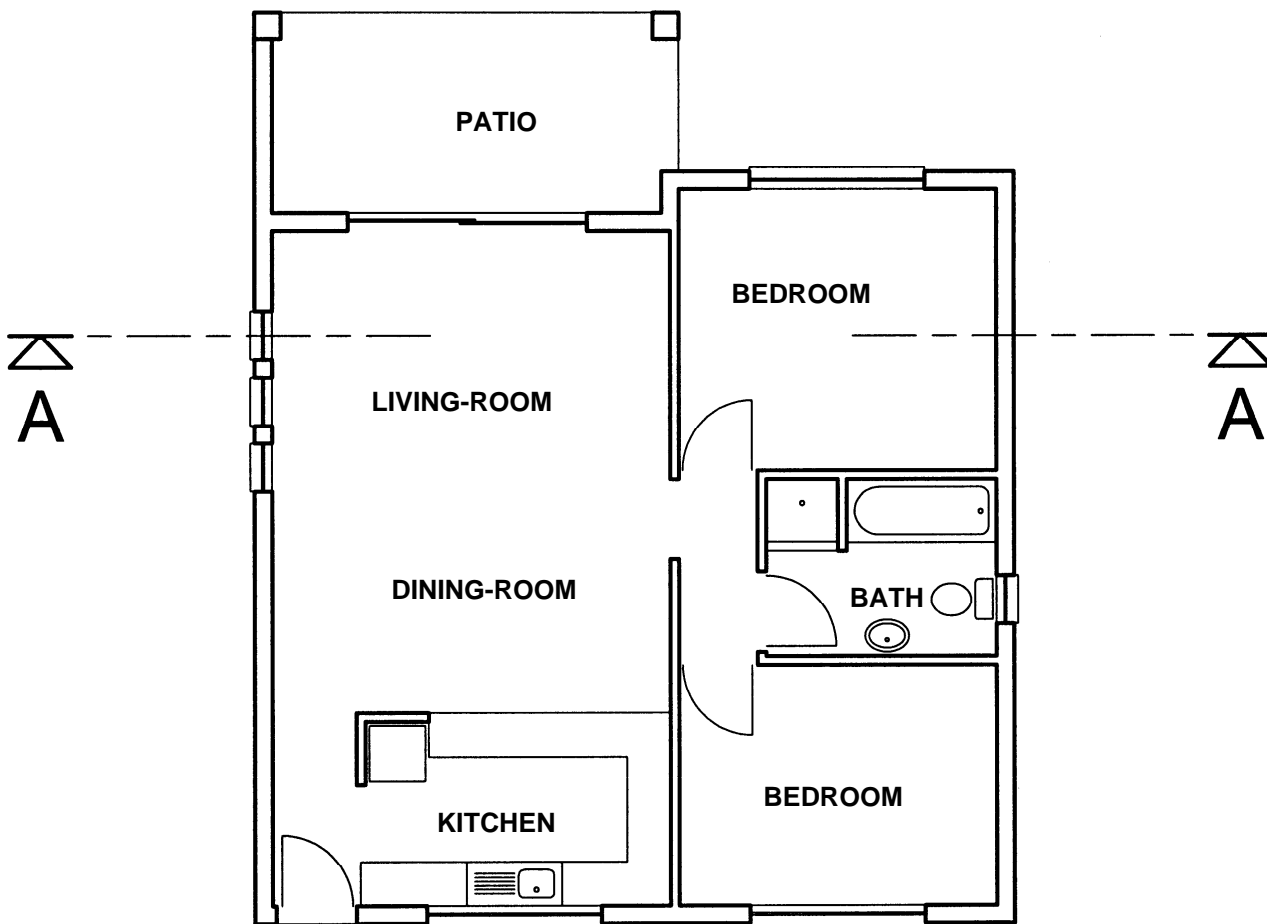

FIGURE 6.1

PLAN SCALE 1:100

EXAMINATION NUMBER: _____

ANSWER SHEET

QUESTION 6.2

EXAMINATION NUMBER: _____

ANSWER SHEET

QUESTION 6.3

EXAMINATION NUMBER: _____

FORMULA SHEET

$$A = \pi D^2/4 \text{ or } \pi \times r^2$$

$$A = L \times B$$

$$A = \frac{1}{2} (b \times h)$$

$$AV = F \times S$$

$$BM = F \times D$$

$$F = m \times g$$

$$F\mu = \mu \times W$$

$$\mu = \text{TAN } \theta$$

$$\text{Tan } \theta = VC/HC$$

$$M = m \times v$$

$$M \times u = m \times v$$

$$P = V \times I$$

$$V = l \times b \times h$$

$$V = \pi r^2 h$$

$$V = l \times R$$

$$VR = \text{Load/Effort distance}$$

$$W = P \times t$$

$$\text{Moment} = F \times \perp S$$