

Teacher instruction:

Ask learners to name the two shapes on the page.
In the first row learners colour the circles red and the squares blue. Can they see the pattern?
Ask them to make the pattern longer. Help learners complete the other rows in the same way.
This is a visual sequencing exercise.

Voltooi die patrone

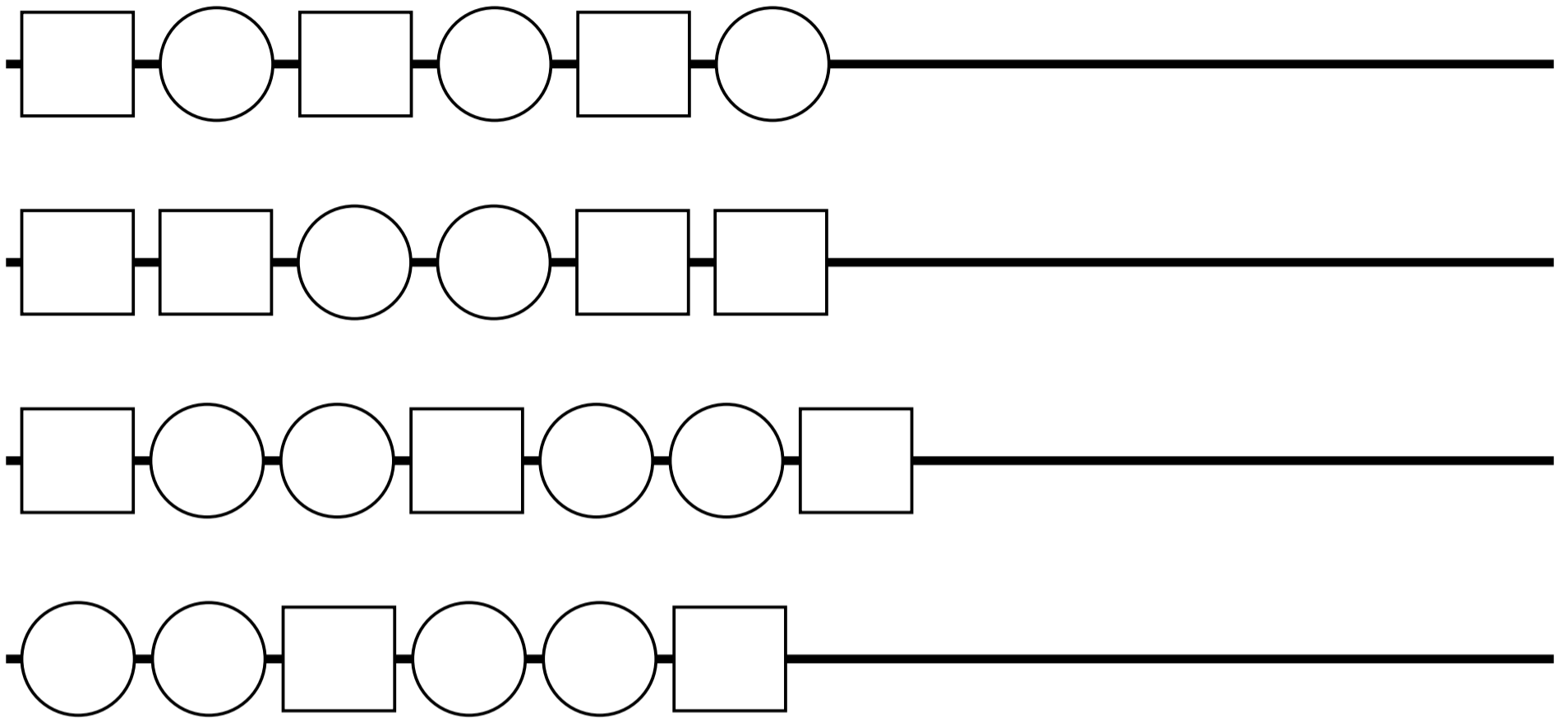

Teacher instruction:

Ask learners to match the item on the left with the correct sense on the right.
Learners trace the pattern, starting at the left and working to the right.
This is a fine-motor co-ordination and directionality activity.

Skryf patrone

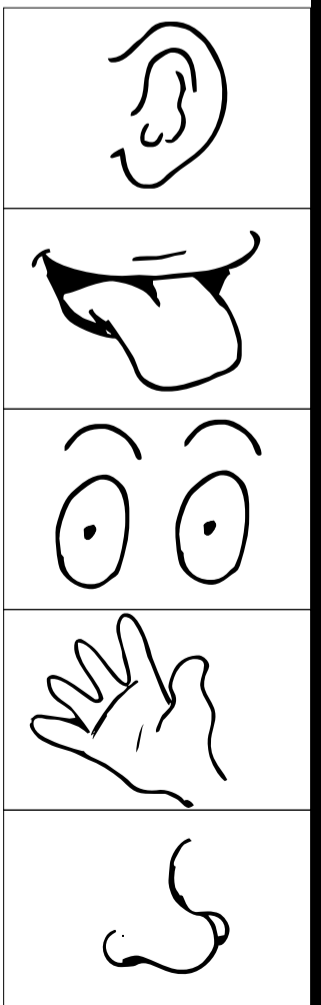
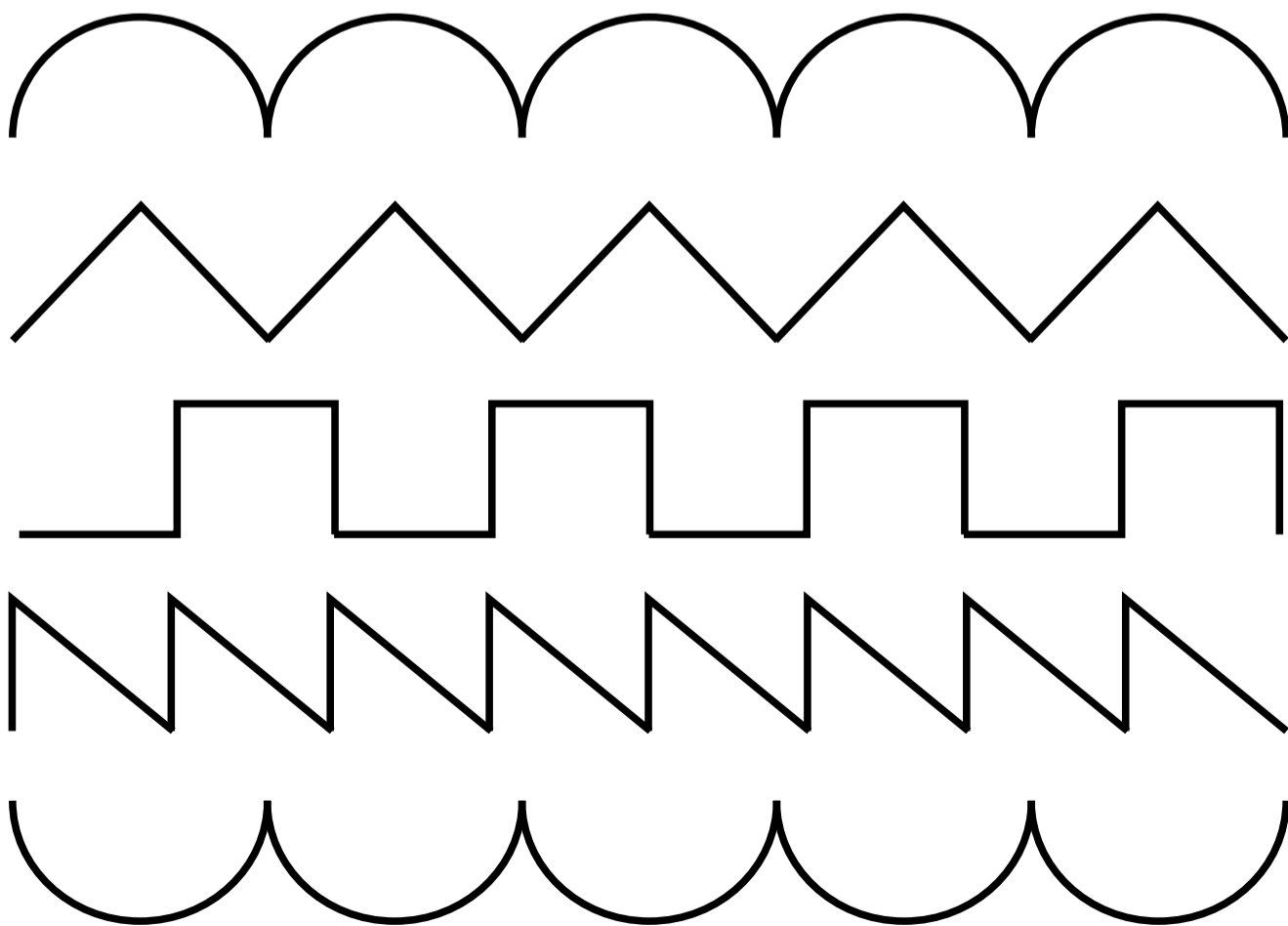
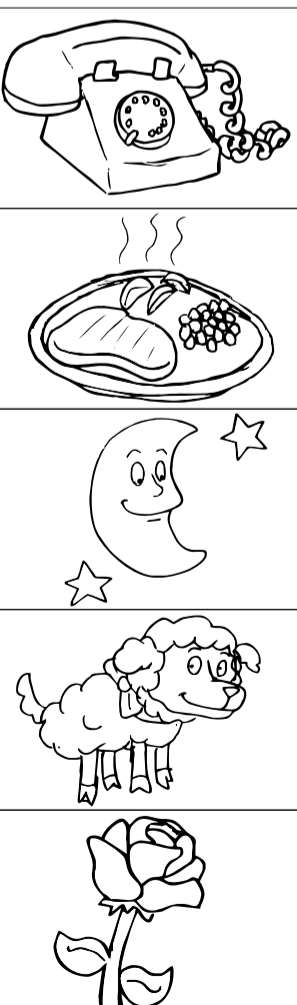

Teacher instruction:

Ask learners what they see on the page. What sound do they hear at the beginning of the word vuvuzela?
How many vuvuzelas can they count? Can they find the pair of vuvuzelas that match? They colour in the matching pair.

On the large vuvuzela at the bottom of the page learners practise tracing the letter 'v'.
This is a visual and auditory discrimination activity. It is also a fine-motor co-ordination exercise.

Vuvuzela pret

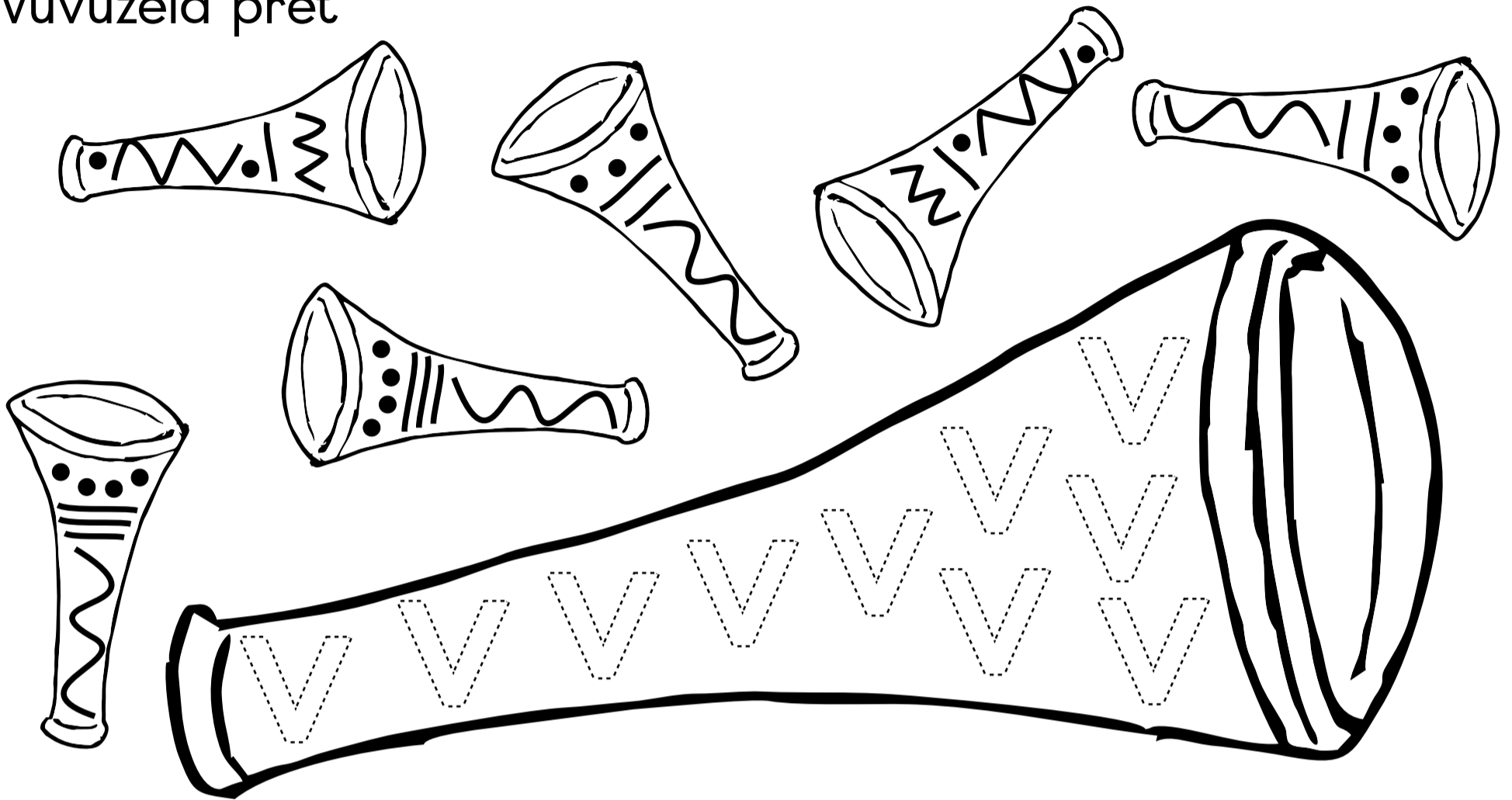

Teacher instruction:

Ask learners to name the five senses. Then ask them to look at each picture in the first column, e.g. the ball, the bear.
Ask what they do with the item. Then ask whether they can feel it, hear it, see it, smell it or taste it.
They colour in the blocks that show which senses they experience the item with. The first row has been completed for you.
This is a reasoning and fine-motor co-ordination exercise.

My sintuie