

**10831**

**LIFE SCIENCES**

**First Paper**

**17 pages**

**LIFE SCIENCES  
(First Paper)****TIME: 2½ hours****MARKS: 150**

---

---

**INSTRUCTIONS AND INFORMATION**

Read the following instructions carefully before answering the questions.

1. Answer ALL the questions.
  2. Write ALL the answers in the ANSWER BOOK.
  3. Start EACH question on a NEW page.
  4. Number the answers correctly according to the numbering system used in this question paper.
  5. If answers are NOT presented according to the instructions of each question, candidates will lose marks.
  6. ALL drawings should be done in pencil and labelled in blue or black ink.
  7. Draw diagrams or flow charts ONLY when requested to do so.
  8. The diagrams in this question paper may NOT necessarily be drawn to scale.
  9. The use of graph paper is NOT permitted.
  10. Non-programmable calculators, protractors and compasses may be used.
  11. Write neatly and legibly.
- 
-

**SECTION A**  
**QUESTION 1**

1.1 Various possible options are provided as answers to the following questions. Choose the correct answer and write only the letter (A – D) next to the question number (1.1.1 – 1.1.5) in the ANSWER BOOK.  
For example: 1.1.6. D

1.1.1 The testes are protected by the . . .

- A prostate gland.
- B scrotum.
- C epididymis.
- D seminiferous tubules.

1.1.2 If a muscle cell in a chimpanzee contains 48 chromosomes, a chimpanzee sperm cell would contain ...

- A 96 chromosomes.
- B 48 chromosomes.
- C 24 chromosomes.
- D 12 chromosomes.

1.1.3 Translation of an mRNA molecule with 48 nucleotides produces a polypeptide of ...

- A 3 amino acids.
- B 12 amino acids.
- C 16 amino acids.
- D 48 amino acids.

1.1.4 In a monohybrid cross between two heterozygous pea plants, the offspring will yield plants with a genotype ratio of ...

- A 3:1.
- B 9:3:3:1.
- C 1:2:1.
- D 1:1.

1.1.5 Contraceptive pills work effectively because the hormone progesterone in them ...

- A prevents the development of egg cells (ova).
- B prevents the thickening of the endometrium.
- C slows down the movement of sperm in the fallopian tubes.
- D promotes the thickening of the endometrium.

5x2=(10)

- 1.2 Give the **correct biological term** for each of the following descriptions. Write only the term next to the question number (1.2.1 – 1.2.6) in the ANSWER BOOK.
- 1.2.1 A fluid produced by the testes and related glands, containing spermatozoa
- 1.2.2 The specific type of nucleic acid on which the anti-codon for protein synthesis is located
- 1.2.3 A genotype consisting of two identical genes/alleles for a particular characteristic
- 1.2.4 A chromosome which is not a sex chromosome
- 1.2.5 The monomer of nucleic acids
- 1.2.6 The structure, in the female reproductive system, that dilates (widens) at the onset of labour
- 1.3 Each of the following questions consists of a **statement** in **COLUMN A** and two **items** in **COLUMN B**. Choose which items relate to the statement. Write down your choice using the following code:

- A If ONLY item A relates to the statement  
B If ONLY item B relates to the statement  
C If BOTH A and B relate to the statement  
D If Neither A nor B relate to the statement

	COLUMN A (STATEMENT)	COLUMN B (ITEMS)
1.3.1	A process of transferring male gametes to the female organ	A. Pollination B. Copulation
1.3.2	A sex-linked disorder	A. Haemophilia B. Albinism
1.3.3	Identical genetic composition	A. Fraternal twins B. Siamese twins
1.3.4	AaBB x AABb	A. Dihybrid cross B. Monohybrid cross
1.3.5	Dominant to genotype i	A. I <sup>A</sup> B. I <sup>B</sup>

5x2=(10)

- 1.4 The flow diagram below shows various processes involved in the human male and female reproductive cycle. Study the diagram and answer the questions that follow.

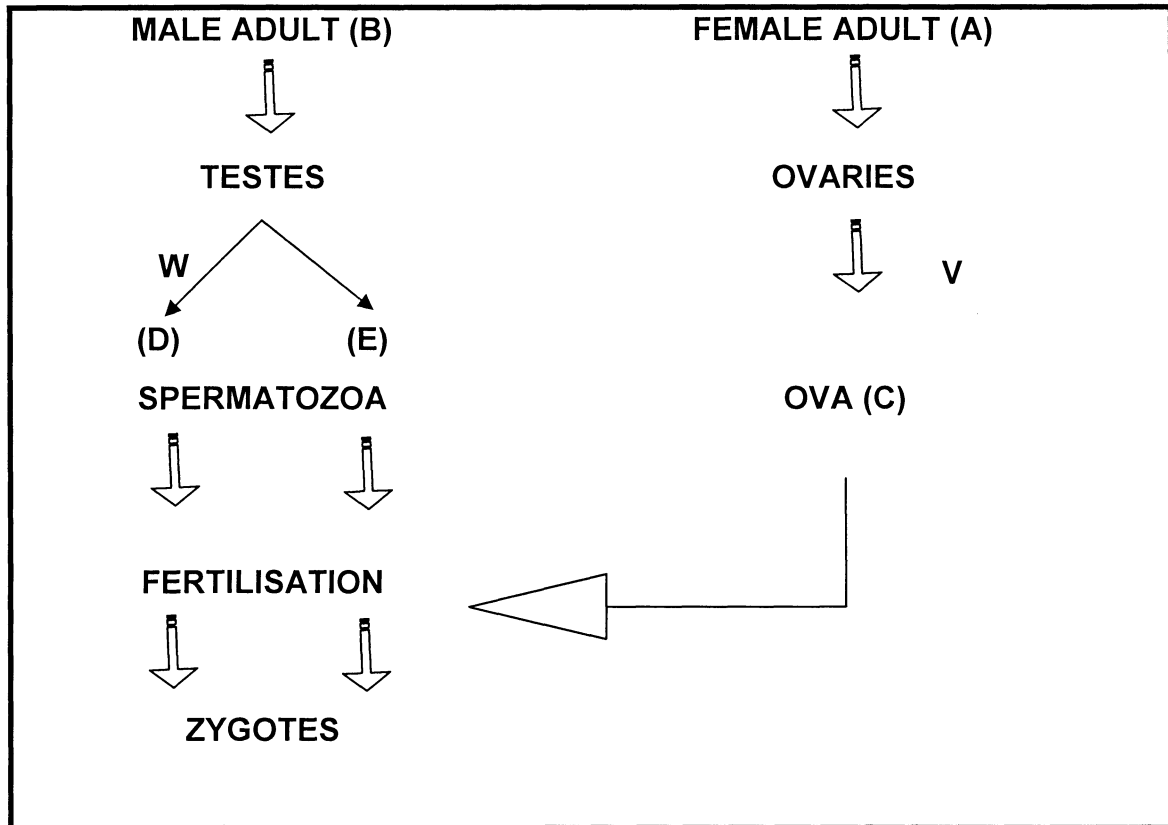

- 1.4.1 Indicate the chromosome make-up ( XX, XY, X or Y) of the different cells represented by the letters A to E. (5)
- 1.4.2 Name the specific processes that occur at V and W respectively. (2)

1.5 Read the passage below and then answer the questions based on it.

In 1973 U.S. biochemists Herbert Boyer and Stanley Cohen made the first recombinant DNA. They cut open plasmids (DNA rings) of the bacterium *Escherichia coli* using a restriction enzyme. Then they added a section of DNA from another plasmid and used ligase to join the two together to re-form the ring of DNA.

This technology was later used and applied to the production of human insulin using bacteria. (The insulin can then be used in the treatment of Diabetes mellitus.)

A diagrammatic representation of this process is shown below.

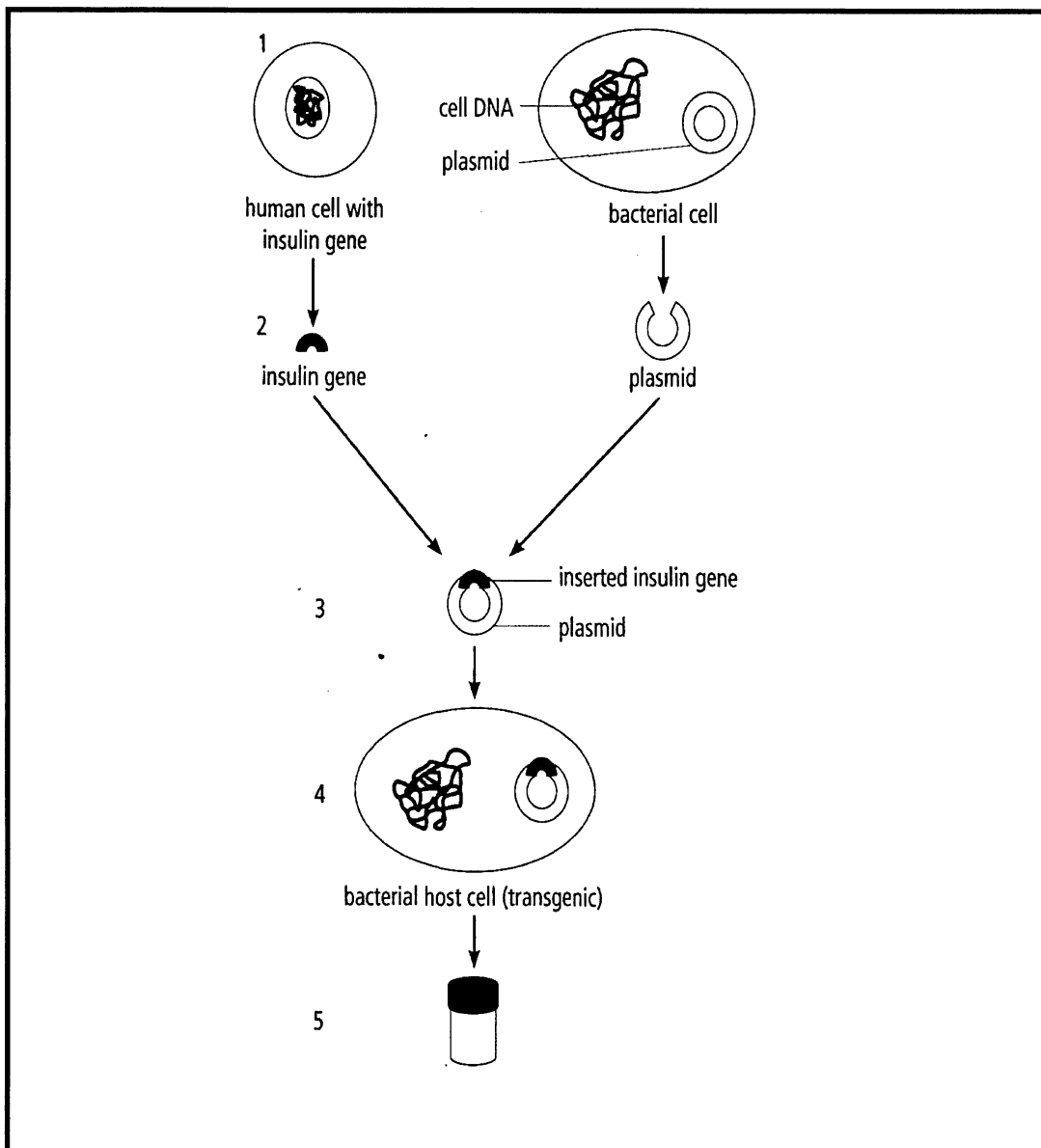

- 1.5.1 The steps involved in this process are listed below. The order is, however, not correct. Place the steps in their correct sequence by writing down only the letters as they occur.
- A The bacterial plasmid ring is cut.
  - B The plasmid is inserted into an *E.coli* bacterium.
  - C Insulin is produced by the bacterium.
  - D The DNA with the insulin gene is added, and the plasmid ring is joined up again.
  - E Human DNA containing the insulin gene is copied.
  - F Millions of bacteria are produced by repeated divisions. (6)
- 1.5.2 State how the rejoining of the plasmid is ensured. (1)
- 1.5.3 What is meant by a “transgenic” bacterium? (1)
- 1.5.4 In the past, the pancreas of certain animals was used to extract insulin. State ONE disadvantage of using animal pancreas to treat Diabetes. (2)

- 1.6 The diagram below represents stages in the process of meiosis. They are however not in the correct sequence. Study the diagram and answer the questions that follow.

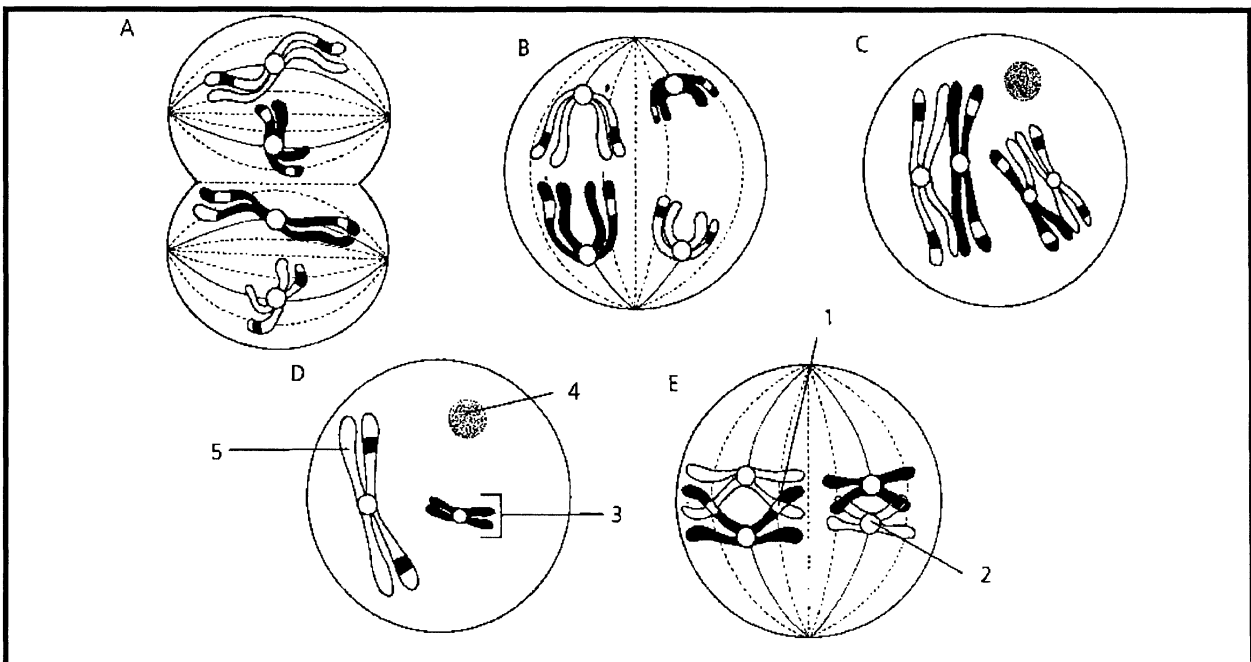

- 1.6.1 Identify the stages B and C. (2)
- 1.6.2 Provide labels for 1, 2 and 3. (3)
- 1.6.3 Name TWO places in the human body where meiosis would occur. (2)

TOTAL SECTION A: 50

**SECTION B****QUESTION 2**

- 2.1 Very complex procedures were used by scientists to determine the finer details of the physical and chemical structure as well as the composition of DNA. Scientists used chemical analysis to provide evidence of the relationships among the nitrogenous bases of DNA. Study the information in the table and answer the questions that follow.

Samples	Percentage of Nitrogenous bases in DNA sample			
	Adenine (A)	Guanine (G)	Cytosine (C)	Thymine (T)
Human liver cells	30.3	19.5	19.9	30.3
Yeast	31.7	(a)	(b)	31.7

- 2.1.1 Compare the amounts of Nitrogenous bases in the sample of human liver cells. (2)
- 2.1.2 Calculate the percentage of Guanine in the DNA sample of yeast. Show all workings. (3)
- 2.1.3 The sequence of bases on a portion of one strand (template) of DNA is **ACGT**. Draw a labelled diagram of the portion of the **complete DNA** molecule. (5)

2.2 The diagram shows the processes of Mitosis and Meiosis.

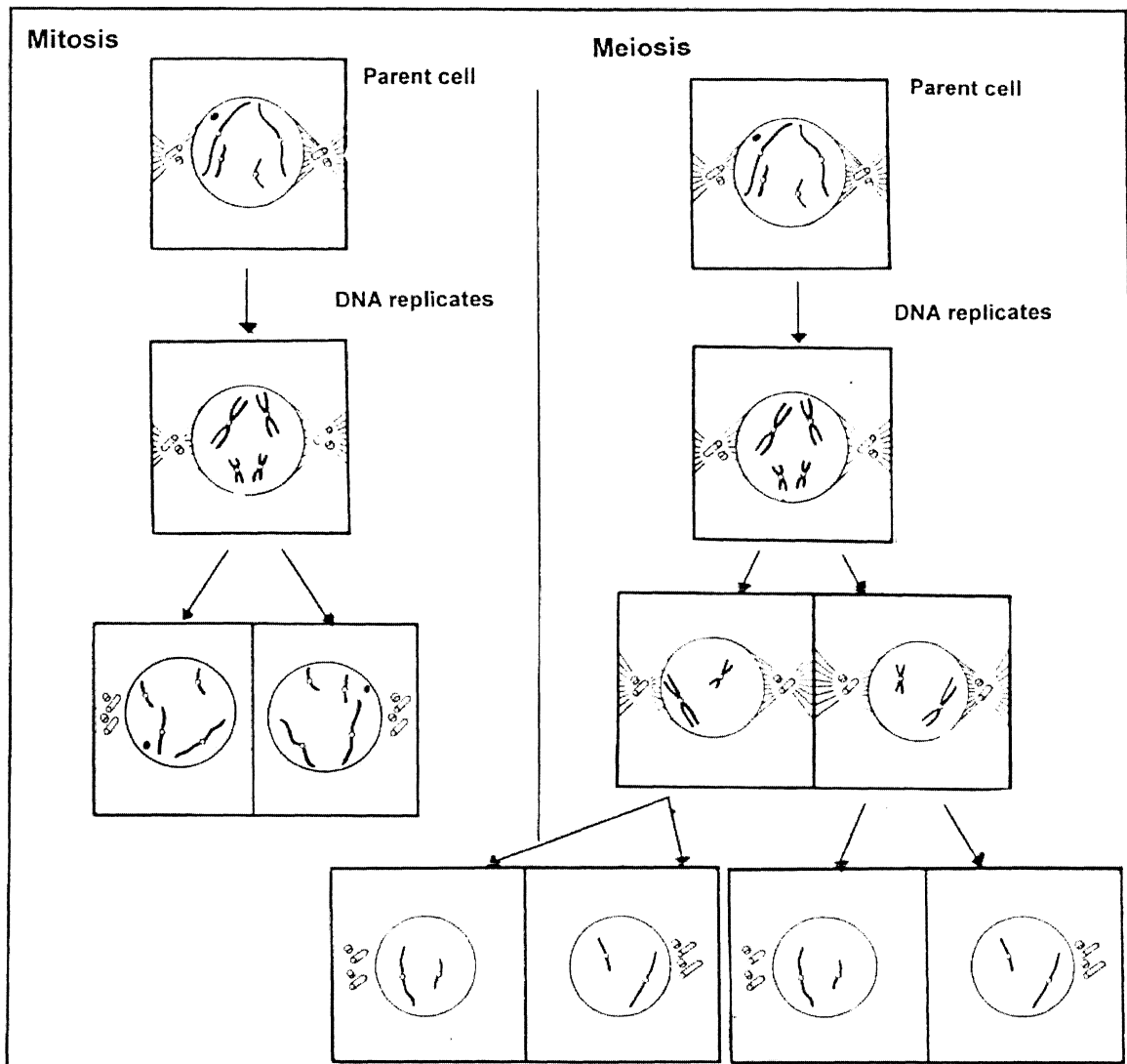

2.2.1 Tabulate TWO **observable** differences between mitosis and meiosis.

(3)

- 2.3 The diagram below, illustrates the process of ribosomal translation, a step in the protein synthesis process.

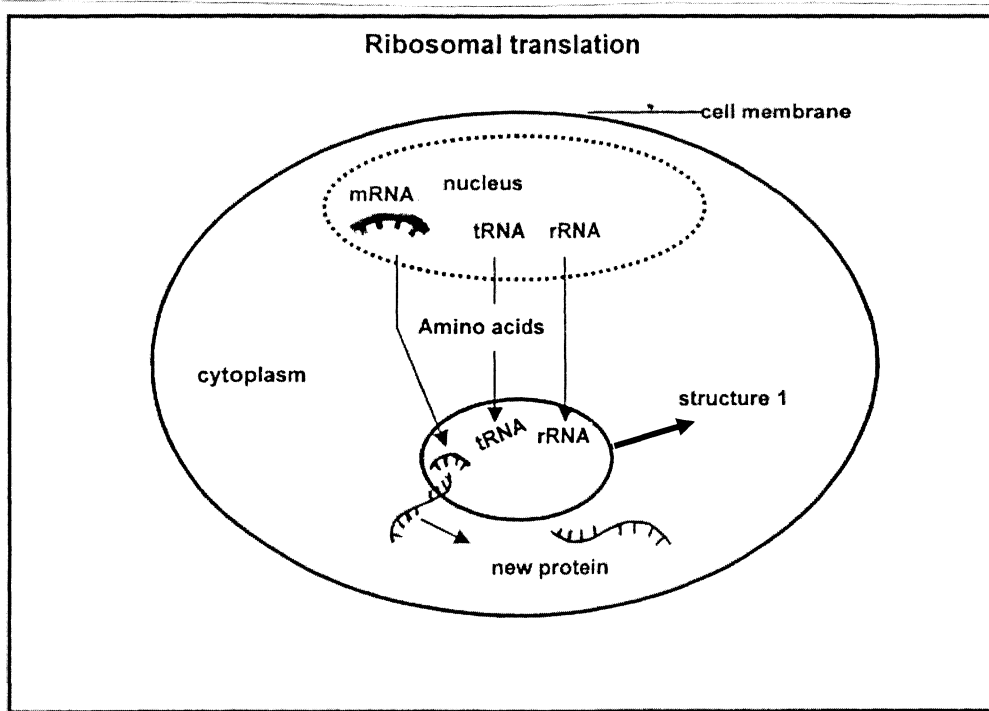

- 2.3.1 Identify structure 1. (1)
- 2.3.2 Differentiate between transcription and translation. (4)
- 2.3.3 Describe the **functional** differences between mRNA, rRNA and tRNA. (3)
- 2.4 The ability in humans to roll or curl the tongue is due to a dominant gene (T), and the inability to do this is due to its recessive allele (t).
- A man who is a tongue roller, and whose mother was not a tongue roller, marries a woman that is not a tongue roller.
- Use a genetic crossing to show the genotypes and phenotypes of the children they might produce. (5)

2.5

**DNA fingerprinting**

No two people (other than identical twins) have exactly the same sequence of bases in their DNA. By detecting these differences in DNA sequences, it is possible to distinguish one person from another. Forensic scientists can use DNA fingerprinting to identify criminals and crime victims from the DNA in blood or small amounts of tissue left at a crime scene. Because DNA fragments that make up a DNA fingerprint are inherited, scientists can use them to resolve questions of paternity.

More than 99 percent of the DNA is exactly the same in all humans. DNA fingerprinting focuses only on the part that tends to differ from one person to the other.

2.5.1 Name TWO uses of DNA fingerprinting according to the article. (2)

2.5.2 Explain ONE argument on which DNA fingerprinting evidence can be rejected. (2)

**[30]**

QUESTION 3

3.1 Study the diagram below and answer the questions that follow.

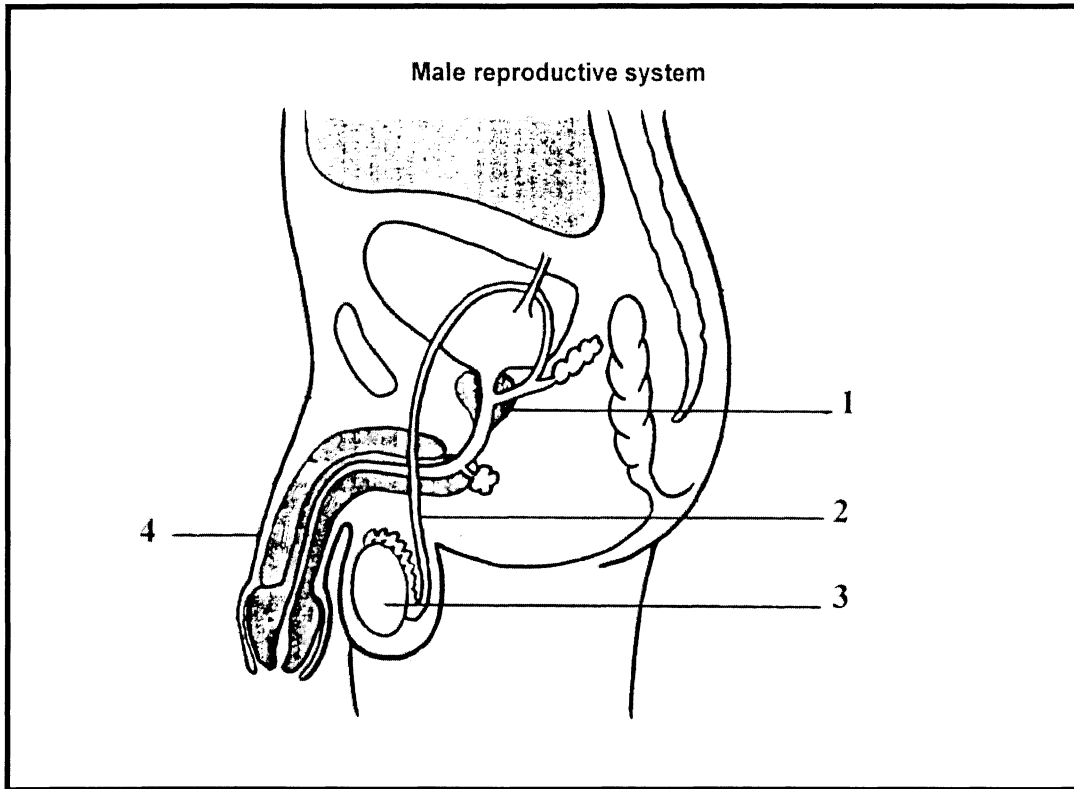

- 3.1.1 (a) Identify the gland labelled 1. (1)
- (b) State the function of the gland labelled 1. (2)
- 3.1.2 Some cultures and religions remove the foreskin of organ number 4. Name the procedure. (1)
- 3.1.3 Gland number 3 secretes an important hormone. Name this hormone. (1)
- 3.1.4 Men who wear tight-fitting underwear or who spend a lot of time in a hot bath sometimes have a low sperm count. Suggest a reason for this. (2)
- 3.1.5 The nucleus of human body cells has a mass of about  $6 \times 10^{-12}$  g. The nuclei of sperm have a mass of  $3 \times 10^{-12}$  g. Suggest a reason for this difference. (1)
- 3.1.6 Which structures in a female are equivalent to the following structures in a male? (2)
- (a) Structure 2
- (b) Structure 3

3.2 The diagram below illustrates the ovarian cycle, hormones and the changes of the endometrium during the menstrual cycle. Study the diagram and answer the questions that follow.

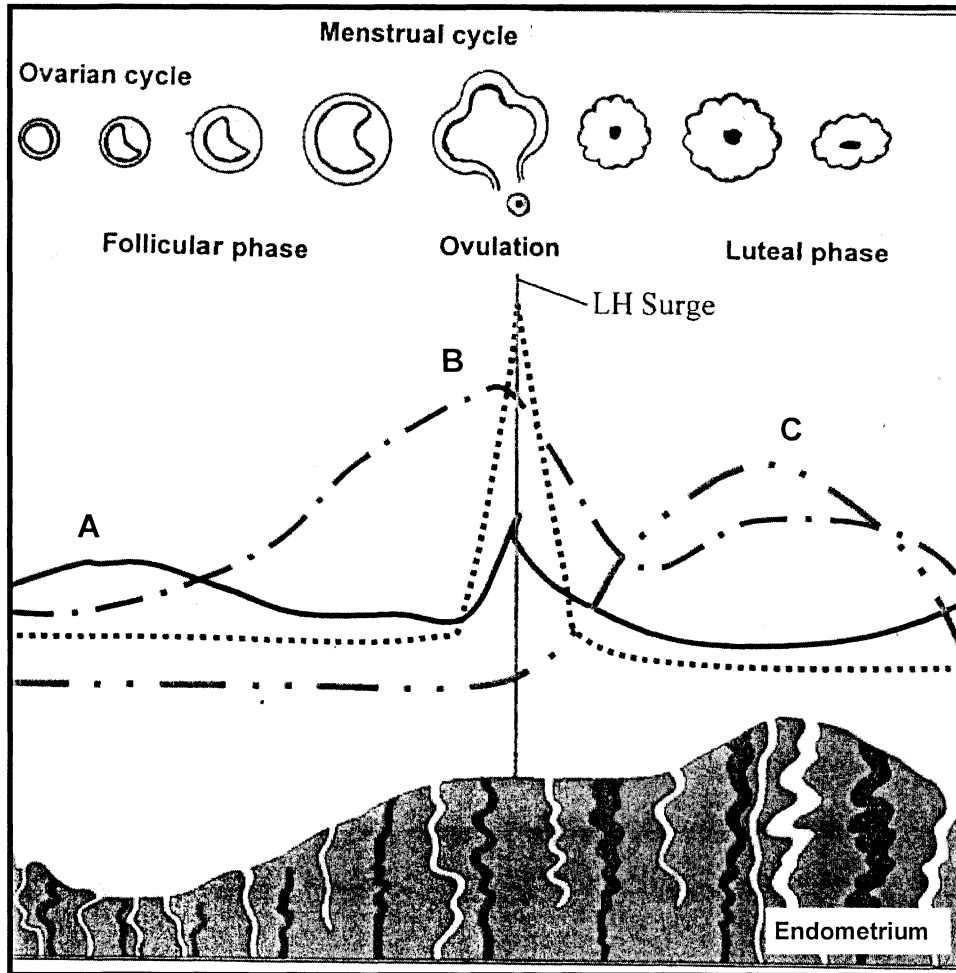

- 3.2.1 Identify the hormones A, B and C. (3)
- 3.2.2 Define the term *ovulation*. (2)
- 3.2.3 After fertilization, the corpus luteum continues to grow and no new follicles are produced. Suggest a reason for this. (2)

- 3.3 The table shows the mass gain of two babies in a study of different types of milk used for feeding until they were one year old. One was fed on milk from normal cows and the other on milk from a genetically modified cow. Both babies were two months old and had the same mass at the beginning of the study.

Source of milk	Mass over time (kg)					
	8 weeks	16 weeks	24 weeks	32 weeks	40 weeks	48 weeks
Mass of baby fed on milk from a genetically modified cow	4.0	6.7	9.1	12.0	14.1	15.9
Mass of baby fed on milk from normal cows	4.0	5.9	8.0	10.2	11.0	11.8

- 3.3.1 Draw bar graphs on the same system of axes to show the trend in mass gain of both babies for the first 24 weeks. (6)
- 3.3.2 (a) Write a general conclusion after studying the graphs. (2)
- (b) From your conclusion, put forward an argument against the use of milk from genetically modified cows for baby food. (2)
- 3.4 Seed companies recommend different planting depths for growing different plants. If you were requested to design an experiment to test whether planting depth has an effect on lettuce and pea seed germination what would be
- 3.4.1 your hypothesis? (2)
- 3.4.2 a factor you would keep constant? (1)
- [30]

**TOTAL SECTION B: 60**

**SECTION C**

**QUESTION 4**

- 4.1 Read the extract based on Sickle-cell anaemia and answer the questions that follow.

Sickle-cell anaemia is a disease characterised by the body producing sickle-shaped red blood corpuscles. This means that the cells are shaped like a “C”. Sickle-shaped cells cannot move easily through the blood vessels. They are stiff, sticky and form clumps in the blood vessels, causing blockage.

Normal red blood corpuscles are bi-concave in shape. They move easily through your blood capillaries.

People suffering from Sickle-cell anaemia have sickle haemoglobin which is different from normal haemoglobin proteins. Sickle-cell anaemia may, however, be advantageous to people, as it creates a mild resistance to malaria.

*(Adapted from U.S Department of Health and Human Services: National Institute of Health)*

- 4.1.1 State ONE advantage that the shape of a normal red blood corpuscle has over the sickle-shaped red blood corpuscle. (1)
- 4.1.2 Sickle-cell anaemia helps people to be resistant to malaria. Suggest a reason why this is possible. (2)

- 4.2 Study the pedigree chart on sickle-cell anaemia and answer the questions that follow.

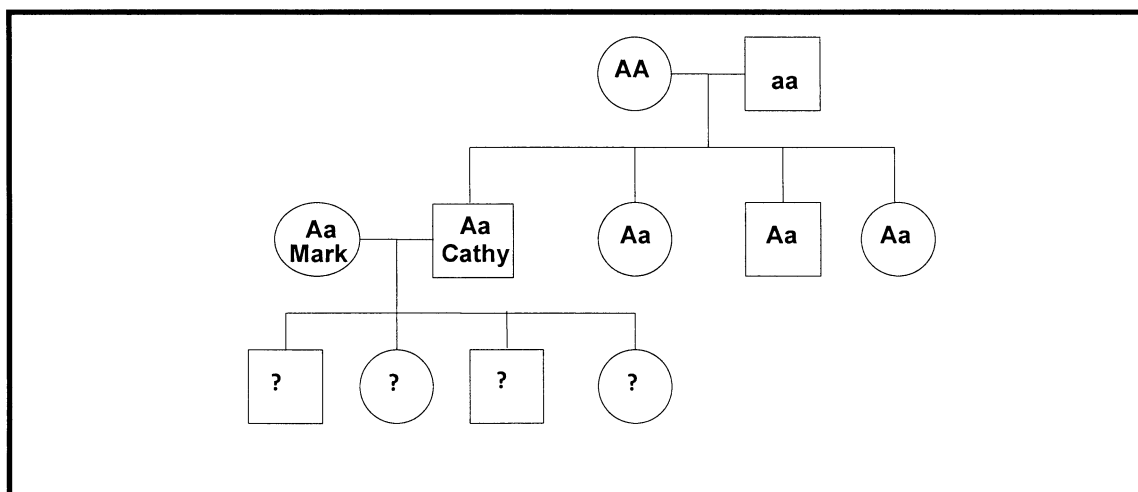

- 4.2.1 Mark and Cathy decide to have children. Identify and write down the percentages of all the possible phenotypes and genotypes of their children. (4)

- 4.2.2 Study the information below of the sequences of the first eight amino acids of two beta haemoglobins found in Cathy's parent's blood.

**Father: val-his-leu-thr-pro-glu-glu-lys**

**Mother: val-his-leu-thr-pro-val-glu-lys**

- (a) Identify the difference between the two forms of proteins. (1)
- (b) Explain a reason why two forms of the same protein have formed. (2)
- 4.3 Read the extract and study the table based on a survey on Stem Cell Research and answer the questions that follow.

*Diabetes Mellitus* is a terminal disease known as a "silent killer" because it attacks the body slowly. The *XCell – Centre Diabetes Mellitus* treatment was offered to twenty-five male (aged 20-30) and twenty-five female (aged 20-30) diabetic patients. They were treated by injecting stem cells into their pancreatic artery via a catheter. Patients who could not undergo the catheterization procedure were allowed to inject the stem cells *intravenously*. Both methods are outpatient procedures.

The results of this treatment showed an overall improvement in stable blood glucose levels.

RESULTS OF STEM CELL TREATMENT COMPLETED IN JULY 2009  
BY TYPE OF DIABETES MELLITUS

Type of Diabetes Mellitus	Improvement counts (number)	No change Counts (number)	Deterioration Counts (number)
Type 1 Diabetes Mellitus	6	11	3
Type 2 Diabetes Mellitus	20	9	1
Total Group Diabetes Mellitus	26	20	4

(Adapted from [www.xcell\\_center.com/treatments/diseases...../diabetes.adpx](http://www.xcell_center.com/treatments/diseases...../diabetes.adpx))

- 4.3.1 Explain what is meant by the word "*intravenously*" as mentioned in the passage above. (1)
- 4.3.2 How many diabetic patients participated in the survey? (1)
- 4.3.3 Identify ONE fixed/controlled variable in the survey. (1)

- 4.3.4 Calculate the percentage of Type 1 and Type 2 diabetic patients that benefited from stem cell treatment. Show all calculations. (4)
- 4.3.5 Use the data in Question 4.3.4 to formulate a valid conclusion based on the results. (2)
- 4.3.6 Give ONE reason why you would say that stem cell research is “unethical”. (1)

4.4 A dietician carried out an investigation on a pregnant woman. The results are shown in the table below. Study the table and answer the questions that follow.

Nutrient	Protein(g)	Calcium(g)	Vitamin D(mg)	Iron(mg)
<b>Before pregnancy</b>	30	0.4	2.5	25
<b>During pregnancy</b>	37	1.2	10	33

- 4.4.1 Provide a caption for the table. (1)
- 4.4.2 Calculate the percentage increase in calcium requirement during pregnancy. Show all calculations. (2)
- 4.4.3 The dietician’s hypothesis was:

“Vitamin D is needed four times more than usual during pregnancy.”

- (a) Can this hypothesis be accepted or should it be rejected? (1)
- (b) Give a reason for your answer to Question 4.4.3(a). (1)

4.5 Read the statement based on the development of the foetus and answer the question that follow.

*“In order for a foetus to stay healthy, the pregnant mother needs to maintain her own as well as her baby’s health and well-being.”*

With reference to the above statement, explain how an expectant mother can ensure prenatal care of her developing foetus. (12)

Synthesis: (3)

**(15)**

**NOTE: NO marks will be awarded for answers in the form of flow charts or diagrams.**

**TOTAL SECTION C: 40**

**TOTAL: 150**